

雷达板接口

### ICL1122芯片电路

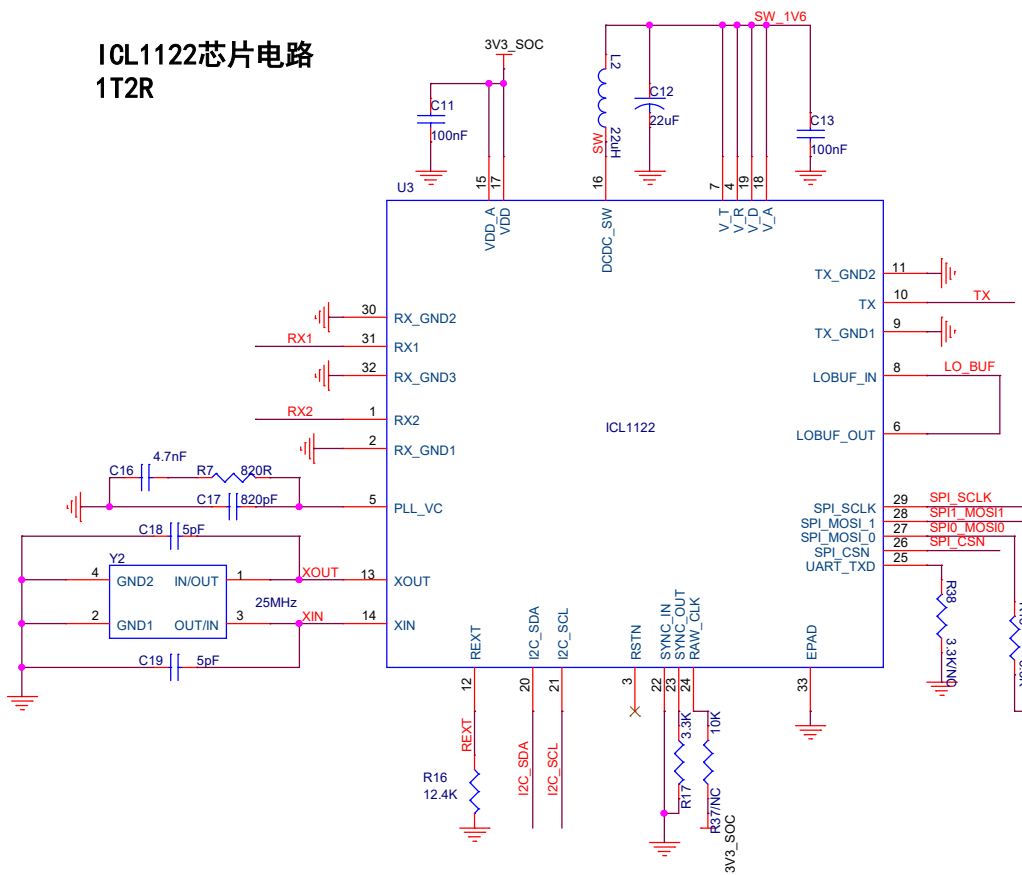

IIC地址位



MOS开关

### PY32F403K1CU6TR MCU芯片电路

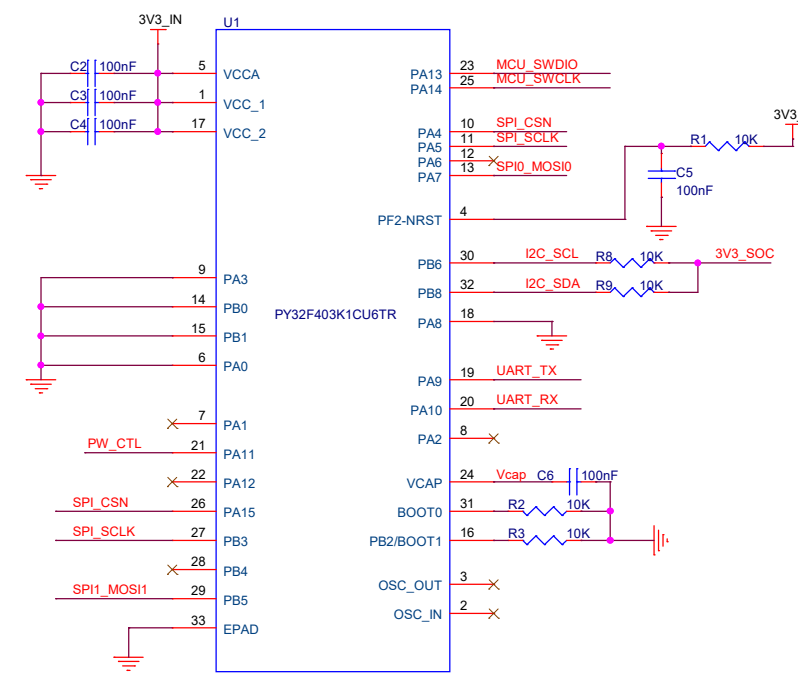

download接口

MCU烧录接口

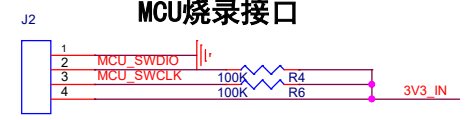

Title		
Size B	Document Number DEV2025	Rev V1.0
Date:	Thursday, September 25, 2025	Sheet 1 of 1