

ICL1112芯片电路 Master

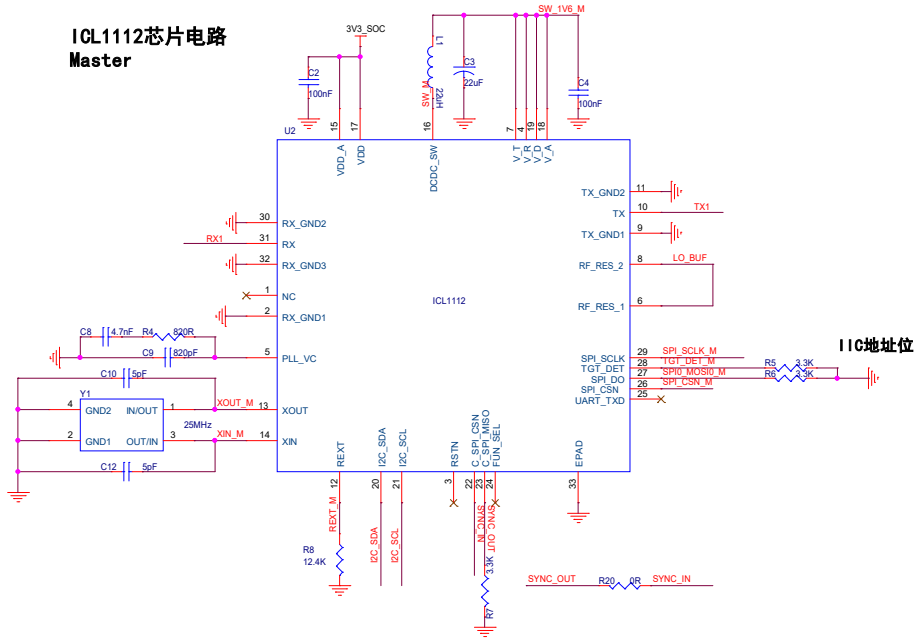

ICL1112芯片电路 Slave

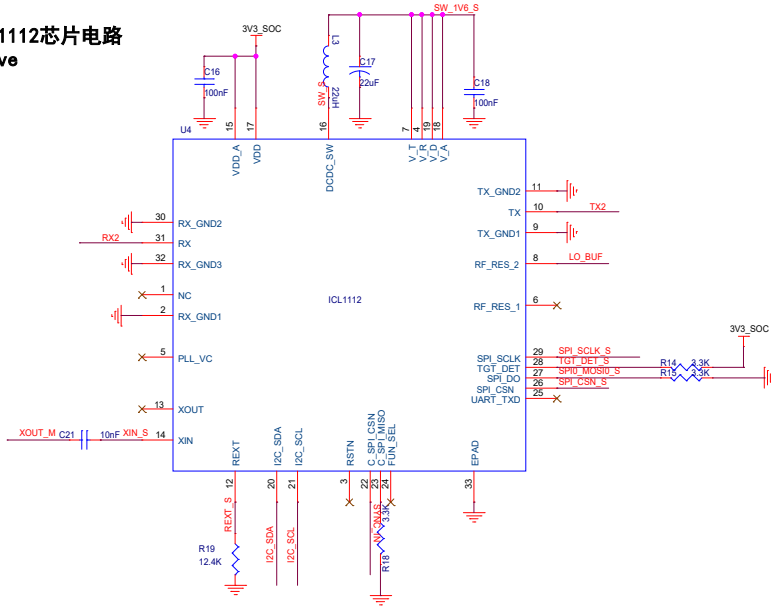

IIC地址位

PY32F403K1CU6TR MCU芯片电路

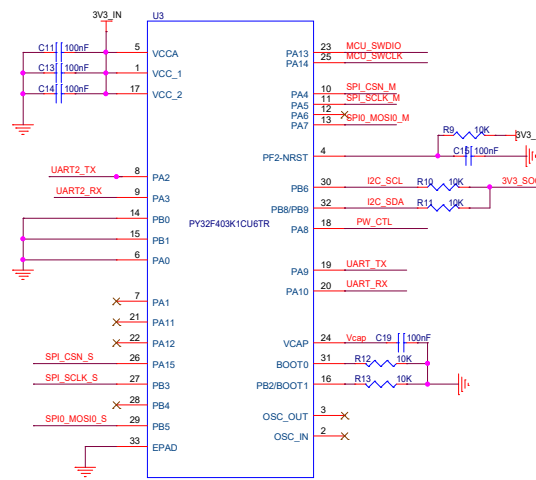

低电平有效

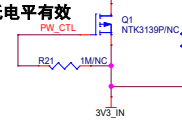

电源 PMOS开关 MOS默认不贴

雷达板接口

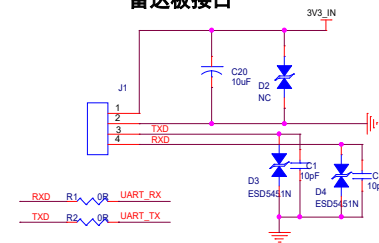

MCU烧录接口

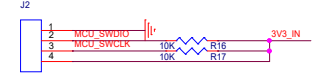

Title		D111V_SCH
Size	Document Number	Rev
C		V1.0
Date:	Wednesday, August 20, 2025	Sheet 1 of 1