

ICL1112芯片电路 1T1R

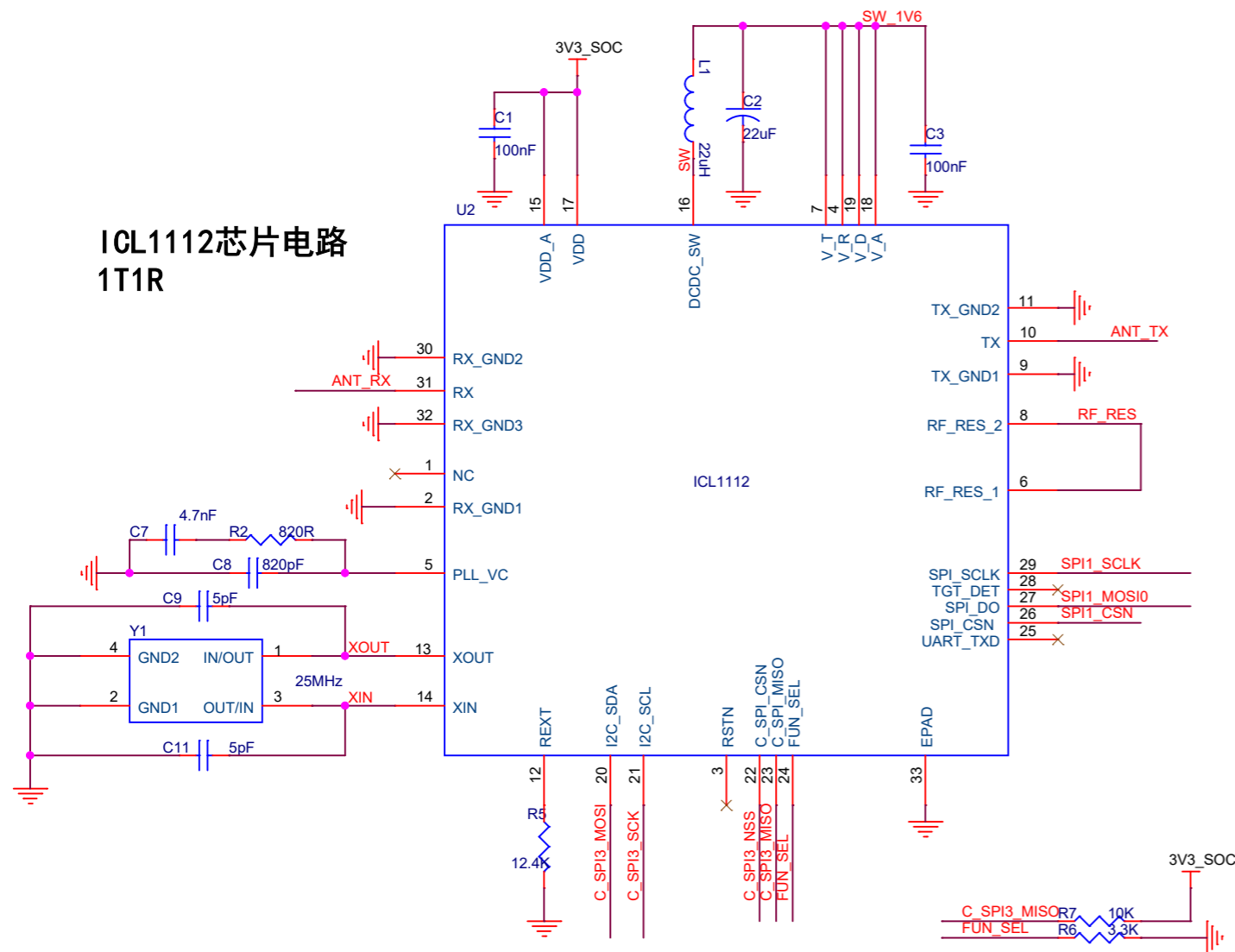

PY32F403K1CU6TR MCU芯片电路

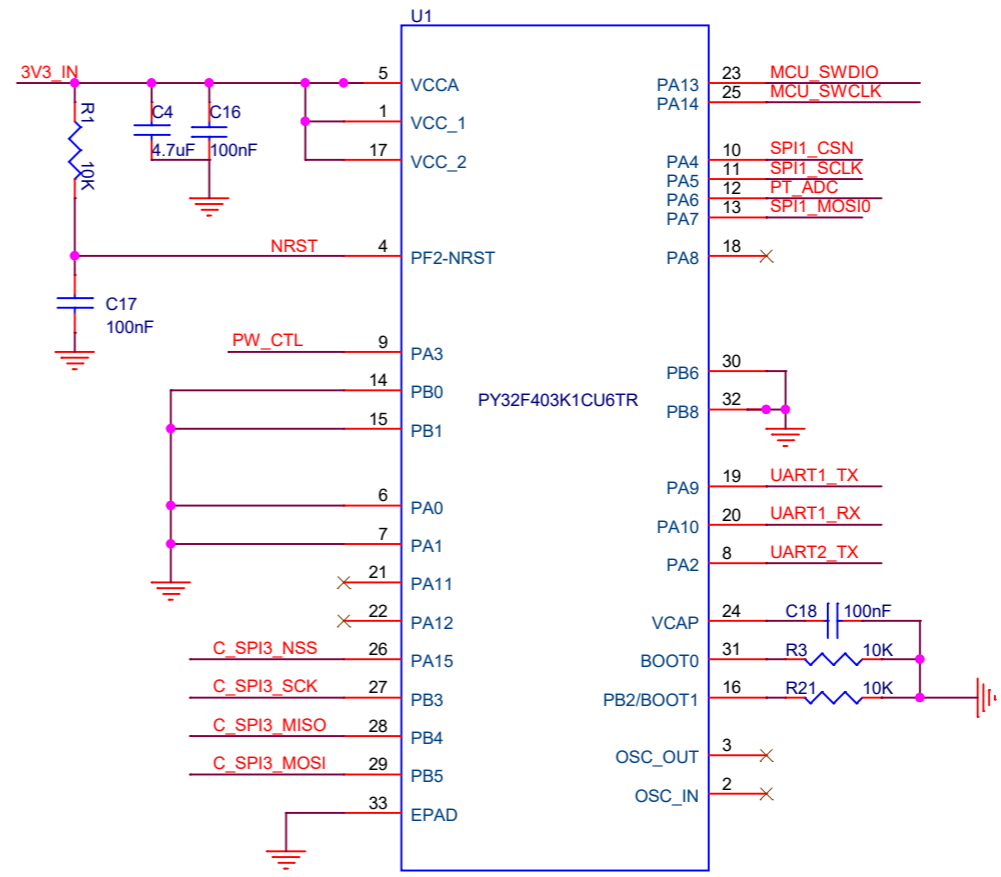

1.27mm间距排针孔

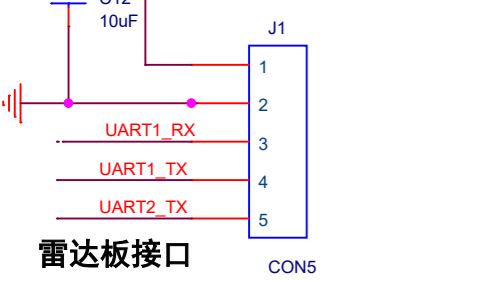

雷达板接口

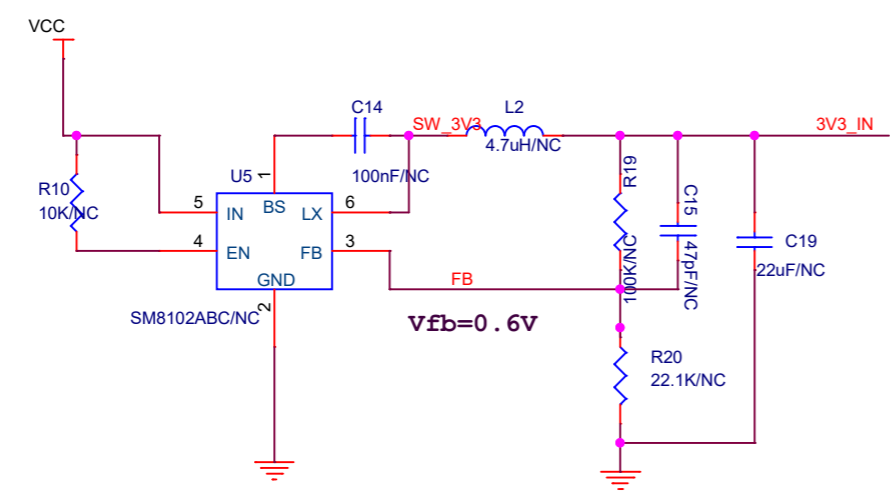
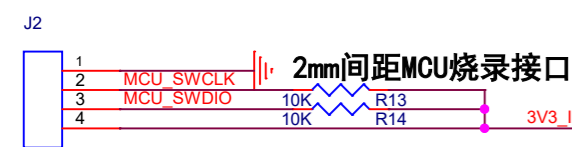

DCDC芯片 5v转化为3v3 默认不贴

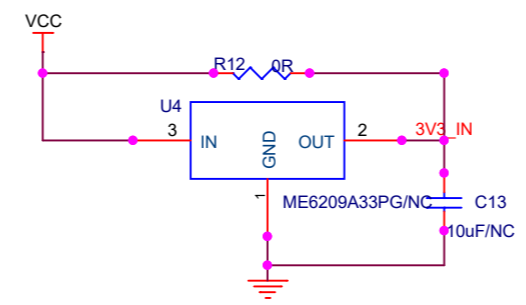

LDO 默认不贴

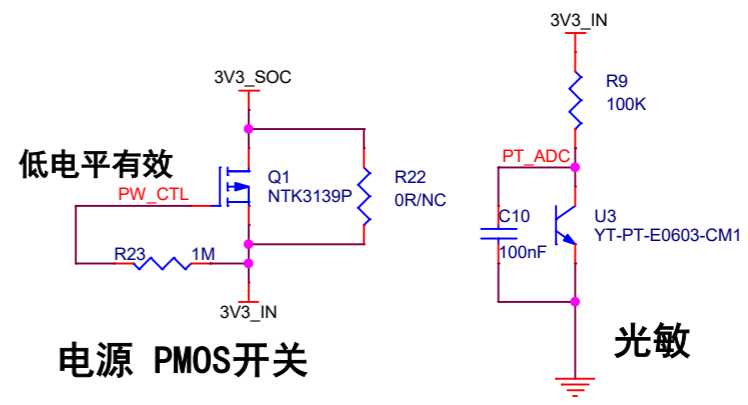

低电平有效

电源 PMOS开关

光敏

Title		
DEV103_Pro_SCH		
Size	Document Number	Rev
B	<Doc>	V2.0
Date:	Monday, August 11, 2025	Sheet 1 of 1